

# Implementing Internet Of Things (IOT) Technology For Real-Time Detection And Monitoring Of LPG Gas Leaks

M Makmun Effendi<sup>1\*</sup>, Ahmad Turmudi Zy<sup>2</sup>, Sanudin<sup>3</sup>

<sup>1,2,3</sup>Program Studi Teknik Informatika, Fakultas Teknik, Universitas Pelita Bangsa Bekasi, Indonesia

Article Info	ABSTRACT
<b>Keywords:</b> LPG, Gas Leak Detection, Internet of Things (IOT), MQ-6 Sensor, Real-Time Monitoring	The Currently, LPG (Liquefied Petroleum Gas) is a vital resource for many households in Indonesia, as highlighted by the government's initiative to convert from kerosene to gas as a cooking fuel. The widespread adoption of LPG is attributed to its affordability and efficiency. However, the flammable nature of LPG poses significant risks, particularly in the event of leaks, which can lead to explosions and fires. This research aims to develop a system that monitors and detects gas leaks in real-time to prevent such hazardous incidents. The proposed system utilizes Internet of Things (IoT) technology, incorporating MQ-6 gas sensors and Raspberry Pi to detect LPG leaks. The MQ-6 sensors are capable of identifying the presence of gas, while the Raspberry Pi processes the data and sends notifications in the event of a leak. The methodology includes literature reviews, user interviews, and data analysis to design an effective monitoring system. The results indicate that the system can accurately detect gas leaks and provide real-time alerts via SMS or a mobile application. In conclusion, this study demonstrates that an IoT-based monitoring and detection system for LPG leaks can significantly enhance safety by enabling prompt responses to gas leaks. This system not only benefits users by facilitating quicker leak management but also contributes to broader safety measures in residential and commercial environments.
This is an open access article under the <a href="https://creativecommons.org/licenses/by-nc/4.0/">CC BY-NC</a> license 	<b>Corresponding Author:</b> M Makmun Effendi Program Studi Teknik Informatika, Fakultas Teknik, Universitas Pelita Bangsa Bekasi, Indonesia <a href="mailto:effendiyan@pelitabangsa.ac.id">effendiyan@pelitabangsa.ac.id</a>

## INTRODUCTION

At the beginning of 2007, 3 kg LPG was introduced to the public to replace kerosene as fuel for cooking because the price was increasing. This 3 kg LPG is a form of conversion carried out by the government where from using kerosene as fuel for cooking, it is switched to 3 kg LPG, and until now LPG is one of the basic needs that is really needed by the community, one of which is because kerosene and The wood used for cooking is very rare, so LPG has become a staple and people are very dependent on using it for cooking (dkk, 2022).

LPG (liquid petroleum gas) is liquefied petroleum gas. The main ingredients in LPG consist of propane (C<sub>3</sub>H<sub>8</sub>) and butane (C<sub>4</sub>H<sub>10</sub>) and small amounts of other elements such as ethane (C<sub>2</sub>H<sub>4</sub>) and pentane (C<sub>5</sub>H<sub>12</sub>). LPG is also commonly used as fuel for buses, tractors, trucks and other vehicles. In the chemical industry, butane and propane are used in the manufacture of plastics, solvents, synthetic fibers, and other organic products. Under

conditions in the open air or atmosphere, LPG will change form to gas. When compared, the volume of LPG in liquid form is smaller than the volume of LPG in gas form. Therefore, LPG is marketed in liquid form and stored in pressurized cylinders made of metal and filled to around 80%-85% of the cylinder capacity (Triyatno, 2018).

The use of LPG has been used in almost all corners of Indonesia so it is necessary to educate the public, especially housewives, regarding the safe use of gas stoves to avoid the risk of LPG gas leaks that can trigger fires, and also efforts made when a gas leak occurs (Darnoto, 2023).

The widespread use of Liquefied Petroleum Gas (LPG) as a cooking fuel in Indonesia has led to significant concerns regarding safety. LPG is highly flammable and can cause severe accidents if not handled properly. The risk of LPG leaks is particularly high due to the frequent use of LPG in households and the potential for human error during installation and maintenance (Puspaningrum et al., 2020).

According to the Ministry of Energy and Mineral Resources, the government has implemented a program to convert from kerosene to gas as a cooking fuel. This initiative aims to reduce air pollution and promote the use of cleaner energy sources. However, the transition to LPG has also increased the risk of accidents, including fires and explosions, which can be attributed to various factors such as poor installation practices, faulty regulators, and inadequate monitoring systems (Kurnia Hadi, 2022).

The detection of LPG leaks is crucial to prevent these accidents. Traditional methods of detecting LPG leaks, such as visual inspections and sniffing for gas, are often unreliable and can be dangerous. Therefore, there is a need for a reliable and efficient system that can monitor and detect LPG leaks in real-time (Hermawan et al., 2019).

Internet of Things (IoT) technology offers a promising solution for monitoring and detecting LPG leaks. IoT involves the connection of devices to the internet, allowing them to communicate and exchange data. This technology can be used to create a system that continuously monitors LPG levels and detects any anomalies, such as leaks, in real-time (Mluyati & Sadi, 2019).

The objective of this research is to design and implement an IoT-based system for detecting and monitoring LPG leaks. The system will utilize sensors to detect LPG levels and a Raspberry Pi to process the data and send real-time notifications to users. This system aims to enhance safety by providing early warnings of potential leaks, thereby reducing the risk of accidents and ensuring a safer environment for users (Nazer & Basry, 2021).

In summary, the detection of LPG leaks is a critical aspect of ensuring safety in households and commercial settings. The proposed IoT-based system offers a reliable and efficient solution for monitoring and detecting LPG leaks, thereby contributing to a safer and more secure environment (Islam et al., 2022).

## METHODS

### Literatur Review

The detection and monitoring of LPG gas leaks is a crucial aspect of ensuring public safety and preventing accidents. In recent years, various technologies have been developed to

address this issue. This review aims to provide an overview of the current state of the art in LPG gas leak detection systems, focusing on the use of Internet of Things (IoT) technology (Tri, 2024).

The system uses LPG gas sensors to detect the presence of gas in the environment, a microcontroller to process the data and send it to the cloud, and a webbased dashboard to display the real-time gas concentration levels and send alerts to users in case of gas leakage . Liquefied Petroleum Gas is a tool that serves to anticipate the safety of a gas leak hazard that can cause explosion and harm to the soul and property. In this final assignment explains how to create a detection system using the MQ-2 gas sensor that is connected to the NODEMCU ESP8266 microcontroller which is then sent to Firebase where the data storage can be viewed in realtime and continued to the Android application, the application used is the MIT App Inventor that has been created to receive notifications in the event of a gas leak. Using a MQ-2 gas sensor with a standard value in the event of gas leakage above 200. This system has fulfilled the rules of the Internet of things because it uses the Internet to connect (Tri, 2024).

Researchers then build and design The system uses LPG gas sensors to detect the presence of gas in the environment, a microcontroller to process the data and send it to the cloud, and a web- based dashboard to display the real-time gas concentration levels and send alerts to users in case of gas leakage. Liquefied Petroleum Gas is a tool that serves to anticipate the safety of a gas leak hazard that can cause explosion and harm to the soul and property. In this final assignment explains how to create a detection system using the MQ-2 gas sensor that is connected to the NODEMCU ESP8266 microcontroller which is then sent to Firebase where the data storage can be viewed in realtime and continued to the Android application, the application used is the MIT App Inventor that has been created to receive notifications in the event of a gas leak. Using a MQ-2 gas sensor with a standard value in the event of gas leakage above 200. This system has fulfilled the rules of the Internet of things because it uses the Internet to connect (Lety Istikhomah Puspita Sari & Ketut Agung Enriko, 2023).

The researchers then developed an LPG gas leak monitoring system by integrating the MQ-2 sensor with a NodeMCU ESP8266 microcontroller and a Wi-Fi communication module to send gas detection data to the Telegram bot platform so as to provide fast and accurate information to user. From the test results, it was found that the MQ-2 sensor can effectively detect LPG gas leaks and provide a fast response. With the help of the Wi-Fi module on the NodeMCU ESP8266, the Telegram bot succeeded in integrating information from the MQ-2 sensor and sending notifications to users with an average duration of  $\pm 7$  seconds (Tambunan & Stefanie, 2023).

Research that is almost similar to Elpiji gas smoke is smoke. Researchers method used is Prototyping. the MQ-2 sensor can detect sources of cigarette smoke up to a distance of 20 cm. The farther the distance from the source of cigarette smoke to the MQ-2 sensor, the lower the level of cigarette smoke (sensor value data) that is read. Vice versa, the closer the source of cigarette smoke is to the MQ-2 sensor, the higher the level of cigarette smoke read by the sensor. Based on the results of the research that has been done, a tool and application

has been successfully created with the title "Indoor Cigarette Smoke Detection Application Based on Arduino Uno and Visual Basic.Net in the Douw-Atarury Airport Waiting Room". from the research tools that have been made on the basis of answering the problem formulation, namely how to make an indoor Cigarette Smoke Detector Application based on Arduino uno and Visual Basic.Net (Petege, 2022).

In subsequent research, the researcher designed an early warning system for detecting and monitoring gas leaks. By utilizing Arduino Uno as the brain or microcontroller, the MQ-2 sensor is an LPG gas leak detection sensor. These devices are integrated into one system where there is a 2.4 GHz wireless protocol. In this way, this tool can send information to the user via the Blynk application installed on the cellphone. IoT (Internet of Things) as a media interface for actual monitoring in real time (Kurnia Hadi, 2022). The system created by the next researcher is a smartphone-based system that utilizes the internet of things, because it functions as an early warning when there is a danger of a gas leak, it can also be connected to any smartphone if you know the token code. Apart from that, this tool can minimize the danger of gas leaks in places that have the potential for gas leaks. This early warning system is equipped with several additional indicators, such as buzzers and LEDs, as replacements if the smartphone connection is lost (Pangestu & Budiarmo, 2023).

In this study the other reseracher using the prototype method in system development. This is because the system is only limited to testing and has not yet reached the implementation stage for the community. The design of this tool consists of the MQ-2 Sensor which is processed by the Wemos D1 R1 microcontroller to detect gas concentrations in the air and give orders to send Telegram message notifications. It is expected to overcome the risk of fire due to LPG gas leakage. From the test results, the sensor takes 5 to 30 seconds to detect gas based on the distance between the tool and the gas cylinder regulator (Egi Noviandra et al., 2022).

The other researcher to make prediction of an increase in consumption demand for LPG allocations with an increase in energy subsidies this year, which was Rp100.68 trillion. the use for LPG gas cylinders is easier. However, the rise of fires caused by gas leaks in the LPG gas cylinders is what makes people afraid to use LPG gas cylinders. Therefore, it is very necessary technology that can replace gas cylinders that cannot be known by humans. So from this research, we can monitor gas leakage so that leakage can be identified through the messenger telegram application. This system is a dangerous gas content to be released by the system that is a gas content of  $\geq 30$  which can be categorized as high gas content, whereas if the system is contaminated with gas content  $\leq 29$  then it can be categorized as low gas content, this system uses internet based MQ-6 sensor of things by using the fuzzy logic method as a receiver on the sensor input. This system will automatically activate the gas leak at high gas levels by activating the alarm / buzzer, led lights, LCD and information about providing information on the gas content obtained by the gas sensor, so that it will continue the notification message from the telegram media application to the owner of the gas cylinder used by Gas leakage and automatic servo motor which is attached to the LPG regulator opens automatically so that it will not cause danger to the gas cylinder that fix it.

This system has tested with a distance sensor of 1 cm to 20 cm and the result is 75% with a maximum distance calculated of 15 cm.

### Research Method

The research is designed to identify and understand the issues related to LPG gas safety. The research also aims to design and implement a system for monitoring and detecting LPG gas leaks based on Internet of Things (IoT) technology.

### Data Collection Methods

The data collection methods used in this research include:

1. Observation: The researcher conducts direct observation of gas LPG usage practices in households and commercial settings. Through this observation, the researcher identifies issues and user needs related to gas safety.
2. Literature Study: The researcher uses various sources of literature to collect data, including books, journals, and written references. This literature study helps the researcher understand relevant theories and previous practices in designing gas leak monitoring systems.

### Design Methods

The design methods used in this research include:

1. Requirement Gathering: The initial stage in the prototyping process is the collection of requirements. These requirements are obtained from the data collection methods, including literature studies, user interviews, and data analysis.
2. Formal Language Representation: In this stage, the researcher draws on the results of the first stage and designs and develops the system mechanisms that will be created or conceived.

### Techniques used include:

#### Menu Structure Design

**Table-1** Design Tools Monitoring Gas

No.	Alat	Keterangan
1.	Raspberry Pi3	Power 5vdc OS raspbian (linux) Pin Gpio Terhubung Wifi
2.	MQ6	Sensor gas Power 3.3vdc
3	Exhaust Fan	
4	Mcp3002	

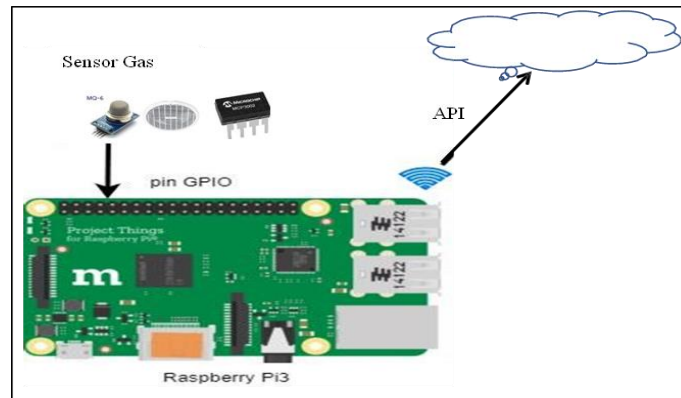

Figure 1. Tools Monitoring Gas

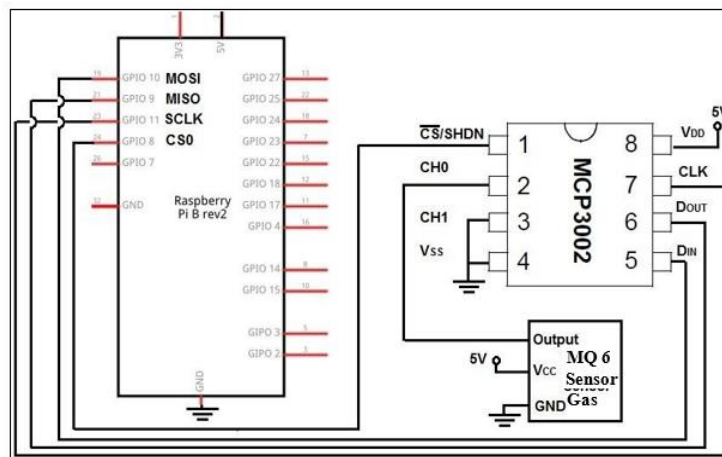

Figure 2. IC MCP 3002

Class Diagram

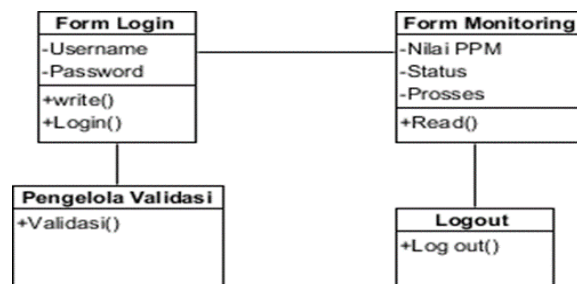
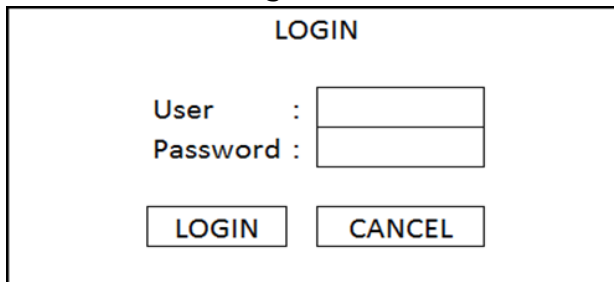

Figure 3. Class Diagram

### User Interface Design



**LOGIN**

User :

Password :

Figure 4. UI Login

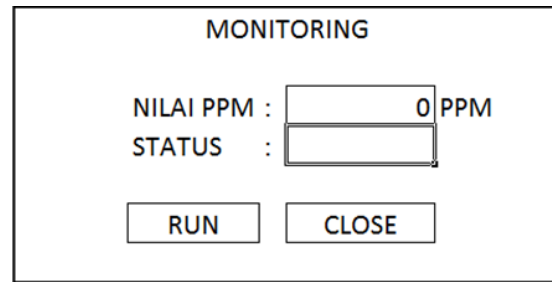

**MONITORING**

NILAI PPM :  PPM

STATUS :

Figure 5. UI Form Monitoring

The implementation of the IoT-based gas leak monitoring system involves several stages:

1. **Hardware Setup:** The hardware components, including the MQ-6 gas sensor, Raspberry Pi, and communication modules, are assembled and configured. The MQ-6 gas sensor is set to ensure accurate readings of LPG gas concentrations.
2. **Software Development:** Software for the Raspberry Pi is developed using the Python programming language. This software is responsible for processing data from the gas sensor, analyzing readings, and sending notifications to users via SMS or mobile applications.
3. **Testing and Validation:** The system is thoroughly tested to validate its performance in detecting gas leaks. Various scenarios are tested to evaluate the accuracy and reliability of the gas leak detection system.
4. **Deployment:** After testing, the system is implemented in several households and commercial settings for real-world testing. Data collection and testing continue to evaluate the system's ability to prevent gas leaks and enhance safety.

## RESULTS AND DISCUSSION

At this stage the designer looks for the most profitable alternative combination in making a mini refrigerator. There are several stages in making this design, namely as follows: The results of this research show that the IoT-based gas leak detection system can effectively detect gas leaks and provide immediate notifications to users. The system uses the MQ-6 gas sensor and Raspberry Pi to detect gas leaks and send notifications via SMS or mobile applications.

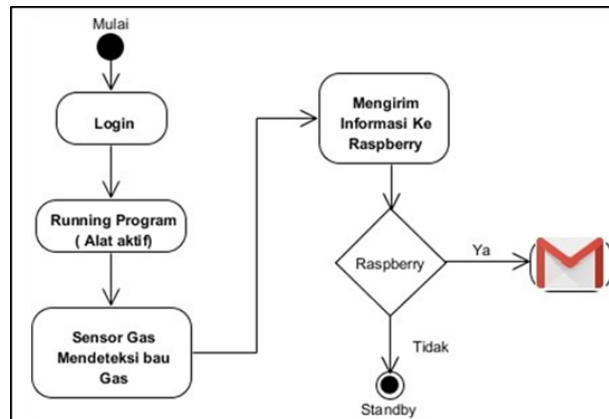

Figure 5. Activity Diagram Design

**Description**

**Form Login**

This form for user access software, must be input user and pasword to access website

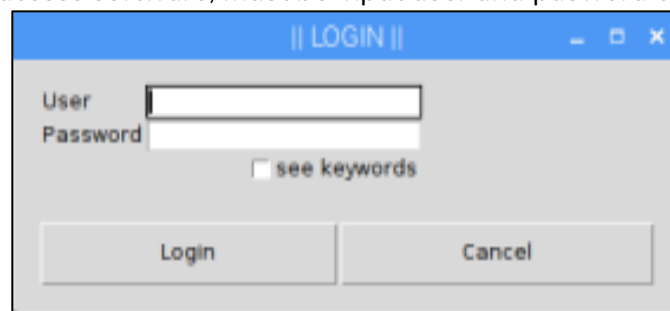

Figure 6. Form Login User

**Form Monitoring**

This Form is function as for access user to do check gas leak. dalam melakukan aksi monitoring Jika ada If any leak gass the monitor display notice data.

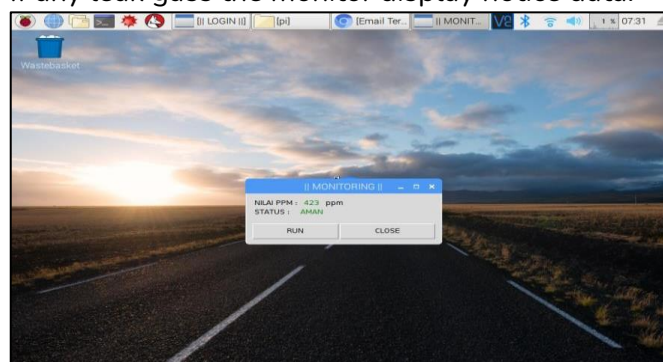

Figure 7. Form Monitoring

### Monitoring Result

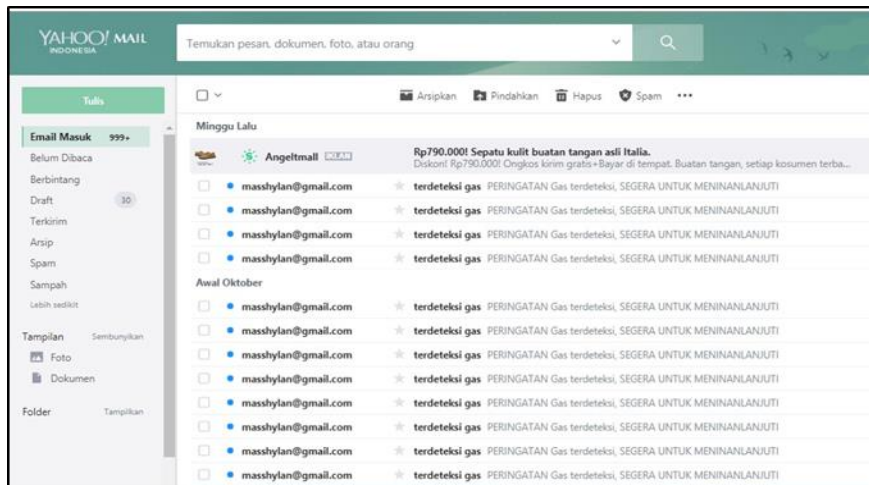

Figure 8. Monitoring Result

### Testing and Validation

The test uses black box testing on the application. Applying Internet of Things technology to monitor and detect LPG gas leaks. The test results of this application are as follows:

Table 2. Result Test Black Box

No.	Item Test	Detail Test	Description	Result Test
1.	Form login	Username	User can't access if wrong username	OK
		Password	User can't access if wrong password	OK
2.	Aplication monitoring	Progrees Bar	Can show progress Bar when application Open	OK
		Run	Detection gas runn	OK
3.	Tools monitoring	Tools aktiv	Display application monitoring	OK
		Sensosr gas	Detection Gas	OK

### CONCLUSION

This research has successfully developed an IoT-based gas leak detection and monitoring system designed to enhance safety in environments where Liquefied Petroleum Gas (LPG) is used. The system integrates hardware components, including the MQ-6 gas sensor and Raspberry Pi, with software developed in Python to provide real-time monitoring and notifications of gas leaks. The key findings of this research are as follows: 1) Effective Detection: The system demonstrated a high level of accuracy in detecting gas leaks, with the MQ-6 sensor effectively measuring gas concentrations within the specified range. 2) Real-Time Notifications: The system is capable of sending immediate notifications via SMS or mobile applications to alert users of potential gas leaks, allowing for prompt action to be

taken.3)User-Friendly Interface: The application developed for monitoring and managing the system is user-friendly, making it accessible for individuals without technical expertise. In conclusion, the IoT-based gas leak detection and monitoring system developed in this research provides a reliable and efficient solution for enhancing safety in environments that use LPG. The successful implementation and testing of the system demonstrate its potential to prevent accidents and protect lives. By leveraging modern technology, this research contributes to the ongoing efforts to improve safety standards in gas usage.

## REFERENCE

- Darnoto, S. (2023). Jurnal Inovasi dan Pengabdian Masyarakat Indonesia " Edukasi Keselamatan Penggunaan Tabung Gas LPG Dalam Rumah Tangga ". *Jurnal Inovasi Dan Pengabdian Masyarakat Indonesia (JIPMI)*, 1(3), 10–13.
- dkk, S. N. (2022). JURNAL AL-TSARWAH | Vol. 5 No. 1, Juni 2022 Program Studi Ekonomi Syariah Pascasarjana IAIN Bone. *Jurnal Al-Tsarwah*, 5(1), 1–16.
- Egi Noviandra, M., Karim, S., & Suswanto. (2022). Sistem Deteksi Kebocoran Gas Lpg Menggunakan Wemos D1 R1 Dengan Sensor Mq-2. *Antivirus: Jurnal Ilmiah Teknik Informatika*, 16(2), 190–199. <https://doi.org/10.35457/antivirus.v16i2.2404>
- Hermawan, D., Hendrawan, A. H., & Ritzkal. (2019). Sistem Deteksi Kebocoran Gas Rumah Tangga dengan menggunakan Peringatan Whatsapp. *Jurnal Teknik UMJ*, 1–8.
- Islam, G. Z., Hossain, M. M., Faruk, M., Nur, F. N., Hasan, N., Khan, K. M., & Tumpa, Z. N. (2022). IoT-Based Automatic Gas Leakage Detection and Fire Protection System. *International Journal of Interactive Mobile Technologies*, 16(21), 49–70. <https://doi.org/10.3991/ijim.v16i21.30311>
- Kurnia Hadi, T. (2022). Analisis Perancangan Alat Pendeteksi Kebocoran Gas LPG Berbasis Sensor MQ-2 dan Arduino Uno. *Jurnal Minfo Polgan*, 11(2), 105–108. <https://doi.org/10.33395/jmp.v11i2.11804>
- Lety Istikhomah Puspita Sari, E., & Ketut Agung Enriko, I. (2023). Design Gas LPG Leak Detection System Based on Internet of Things. *JIM: Jurnal Ilmiah Mahasiswa Pendidikan Sejarah*, 8(3), 1053–1060.
- Mluyati, S., & Sadi, S. (2019). INTERNET OF THINGS (IoT) PADA PROTOTYPE PENDETEKSI KEBOCORAN GAS BERBASIS MQ-2 dan SIM800L. *Jurnal Teknik*, 7(2). <https://doi.org/10.31000/jt.v7i2.1358>
- Nazer, H. R., & Basry, A. (2021). Rancang Bangun Alat Sensor Pendeteksi Asap Rokok Di Dalam Area Stadion Gelora Bung Karno Berbasis Raspberry Pi. *Tekinfo: Jurnal Bidang Teknik Industri Dan Teknik Informatika*, 22(1), 40–55. <https://doi.org/10.37817/tekinfo.v22i1.1179>
- Pangestu, B. H., & Budiarmo, Z. (2023). Sistem Peringatan Dini Kebocoran Gas Pada Waterheater Menggunakan Sensor Mq-2 Berbasis IoT. *Jurnal Jupiter*, 15(1), 682–690.
- Petege, S. (2022). Aplikasi Pendeteksi Asap Rokok Di Dalam Ruangan Berbasis Arduino Uno Dan Visual Basic.Net Pada Ruang Tunggu Bandara Douw-Atarury Nabire. *Jurnal Teknologi Dan Rekayasa*, 7(2), 60–71.
- Puspaningrum, A. S., Firdaus, F., Ahmad, I., & Anggono, H. (2020). Perancangan Alat Deteksi

- Kebocoran Gas Pada Perangkat Mobile Android Dengan Sensor Mq-2. *Jurnal Teknologi Dan Sistem Tertanam*, 1(1), 1. <https://doi.org/10.33365/jtst.v1i1.714>
- Tambunan, S., & Stefanie, A. (2023). Monitoring Kebocoran Gas Lpg Menggunakan Sensor Mq-2 Pada Rumah Dengan Notifikasi Bot Telegram. *JATI (Jurnal Mahasiswa Teknik Informatika)*, 7(2), 1423–1228. <https://doi.org/10.36040/jati.v7i2.6815>
- Tri, A. (2024). *Pembangunan Sistem Pendeteksi Kebocoran Gas Lpg Berbasis Iot*. 10(1), 487–492.
- Triyatno, J. (2018). Perbandingan Penggunaan Gas Alam Terhadap Lpg Dalam Memenuhi Kebutuhan Rumah Tangga Di Bontang. *Al Ulum: Jurnal Sains Dan Teknologi*, 4(1), 14. <https://doi.org/10.31602/ajst.v4i1.1555>