

# Design of A Website-Based Repository System With The Boyer-Moore Algorithm for Efficient Document Management

Rizky Maulana<sup>1\*</sup>, Rinna Rachmatika<sup>2</sup>

Informatics Engineering Study Program, Faculty of Computer Science, Universitas Pamulang

The development of information technology demands a system capable of managing documents effectively and efficiently. PT. Prasty Mitra Solusindo still faces obstacles in document archiving, which often causes difficulties in finding the required documents. This research aims to design and develop a web-based repository system by implementing the Boyer-Moore algorithm to improve the efficiency of document retrieval. The development method used is Rapid Application Development (RAD), consisting of planning, design, construction, and implementation stages. The Boyer-Moore algorithm is applied as a text-search method to accelerate the process of document retrieval based on keywords. The testing results show that the developed repository system can significantly speed up the document retrieval process compared to conventional search methods. In addition, the system also supports document management features such as uploading, categorization, and access control. Therefore, this web-based repository system can assist the company in managing documents more quickly, systematically, and easily accessible.

**Keywords:** Repository, Website, Boyer-Moore, Document Management, Retrieval.

This is an open access article under the [CC BY-NC](#) license



## Corresponding Author:

Rizky Maulana

Informatics Engineering Study Program, Faculty of Computer Science, Universitas Pamulang, Tangerang

ikimotovlogrevo@gmail.com

## 1. Introduction

Introduction: The development of information technology in the era of globalization has brought about significant changes in the way organizations manage data and documents. Archive storage processes, previously physical, have now shifted to digital formats to facilitate easy access and increase efficiency. Web-based repositories are an alternative solution that allows users to store, search, and manage documents more effectively [1].

With the rapid advancement of information and communication technology in today's global era, the use of web-based repositories has become an effective alternative for more practical document management [2]. One company engaged in licensing services is PT. Prasty Mitra Solusindo, located in Rukan Citywalk, Pondok Cabe Udik, Pamulang. The company was founded in 2017 and has a core team of five people.

Challenges currently being faced by PT. Prasty Mitra Solusindo include inefficient document management or physical damage. Archive storage is still vulnerable to loss, as hard copies are stored in a single cabinet. Furthermore, access difficulties in finding documents require significant time, requiring users to search through each cabinet and PDF file stored on the computer. Furthermore, document security is vulnerable to loss or theft because hard copies of important documents, such as certificates or company permits, can become targets for theft. Uncontrolled access to document storage space exacerbates this risk [3]. Therefore, a fast and efficient search algorithm is required. The Boyer-Moore algorithm is the right choice for this system due to its superior string search speed compared to other conventional search algorithms. This algorithm uses a right-to-left approach in the string matching process and applies two important heuristics: the bad character rule and the good suffix rule, making it highly effective in accelerating document searches based on specific keywords.

The Rapid Application Development (RAD) System Development Model is an approach that focuses on accelerating the development process by minimizing initial planning and emphasizing a short iteration approach, with each iteration refining and adding features. In this model, users are actively involved throughout the development process to ensure that the final result meets their needs [4].

## 2. Literature Review

The development of digital information systems has significantly transformed organizational document management processes, shifting from conventional physical archives to integrated electronic repository systems. A repository system functions as a centralized platform that enables the storage, classification, and retrieval of digital documents efficiently and securely [5]. Previous studies indicate that web-based repository systems improve organizational performance by facilitating faster document access, reducing the risk of physical damage or loss, and enhancing document security through access control mechanisms. In the context of information retrieval, the effectiveness of a repository system largely depends on the search algorithm used to locate documents. The Boyer Moore algorithm is widely recognized as one of the most efficient string-matching algorithms because it applies heuristic techniques such as the *bad character rule* and the *good suffix rule* to accelerate the matching process, allowing the algorithm to skip unnecessary comparisons during the search operation [6]. Empirical research demonstrates that the Boyer Moore algorithm performs significantly faster than conventional sequential search techniques in text processing and digital archive retrieval systems, making it suitable for applications that require rapid keyword-based document searches.

Despite the advantages of repository-based document management systems, several studies highlight persistent challenges in their implementation, particularly in small or medium-sized organizations that still rely on manual archiving methods [7]. Manual document storage often results in inefficient retrieval processes, limited accessibility, and higher risks of document loss or duplication. Although previous research has explored the application of web-based information systems and search algorithms in digital archiving, many implementations still focus primarily on system development without evaluating how search algorithms specifically improve retrieval efficiency in real organizational contexts [8]. This limitation indicates a research gap related to the integration of efficient search algorithms with practical document management systems that address real operational problems. Based on this gap, the research problem of this study can be formulated as follows: how can a web-based repository system utilizing the Boyer Moore algorithm improve the efficiency and effectiveness of document management and retrieval processes in an organizational environment. To address this problem, this research aims to design and implement a repository system that integrates the Boyer Moore algorithm as the core search mechanism in order to enhance document retrieval speed and support more efficient digital document management.

## 3. Methods

This research methodology explains the stages used in the web-based repository development process, including data collection, application development models, and data analysis techniques, as follows:

1. Observation: The author conducted direct observations of the manual document management system at PT. Prasty Mitra Solusindo to understand the processes and challenges faced in archiving physical documents.
2. Interviews: Interviews were conducted with relevant parties at PT. Prasty Mitra Solusindo, including administrative and management staff, to obtain an overview of the needs of a web-based repository.

3. Literature Review: This study gathered information from various written sources, such as scientific books, and utilized access to online media to obtain additional data to support the development of this thesis.

### **Application Development Model**

Based on research [9], there are three stages in software development using the RAD method:

1. Requirements Planning, the first step in the software development process using the RAD method. This stage aims to understand user needs and expectations and determine the project scope[10].
2. User Design: This stage focuses on designing the interface and user experience using an iterative approach. The primary goal is to ensure that the design meets user needs and expectations [11].
3. Implementation: This stage involves coding, testing, and deploying the application. The focus is on rapid and iterative development, with continuous testing to ensure quality.

### **Data Collection Techniques**

Data were collected through observation, interviews, and literature review. Observation was conducted by directly examining the existing manual document archiving process to identify operational problems such as inefficient searches and risk of document loss. Interviews were carried out with administrative staff and management to determine system requirements, including document storage, categorization, and access control. Literature review was conducted using books, journals, and online sources to obtain theoretical foundations related to repository systems, search algorithms, and information system development.

### **System Development Model (RAD)**

The system was developed using the Rapid Application Development (RAD) model. The requirements planning stage identified user needs and defined system features such as document upload, classification, and search functions. The user design stage involved designing the interface, database structure, and system models such as use case diagrams and ERD to describe user interaction with the system. The implementation stage included system coding, integration of features, and testing to ensure the application functions according to user requirements.

### **Implementation of the Boyer Moore Algorithm**

The Boyer Moore algorithm is used in the document search feature to accelerate keyword matching. The algorithm compares search patterns with document titles or archive numbers from right to left using the bad character and good suffix heuristics. This mechanism allows the system to skip unnecessary comparisons, resulting in faster document retrieval compared to conventional search methods.

### **Testing and Data Analysis**

System testing was conducted by comparing document retrieval time using the Boyer Moore algorithm and conventional search methods. Several document titles were used as test data to measure search performance. The results were analyzed by comparing search duration and evaluating whether the algorithm improves efficiency in the document retrieval process.

## **4. Result And Discussion**

Based on the analysis of the system currently in operation, the following is an explanation of the working mechanisms and the division of roles and responsibilities of each party contributing to the system's operational process:

### **a. Director**

The director is responsible for monitoring and viewing document data. The director can enter new documents, view document data charts, and search for documents.

Design of A Website-Based Repository System With The Boyer-Moore Algorithm for Efficient Document Management. Rizky Maulana et.al

b. Admin

The admin is responsible for creating new user accounts by providing the necessary information, such as name, username, password, and the permissions each user has for the system's features. Other admin duties include managing all data, new entries, borrowing, charting, document searching, classification, creating archives, processing units, locations, media, database imports, and database backups.

c. Employees

Employees are responsible for viewing all data, entering new documents, and viewing chart charts.

**Implementation of the Boyer-Moore Algorithm**

a. PreBmBc Steps (Occurrence Heuristic)

Text (T) = SURAT TAGIHAN PAJAK DAERAH

Pattern (P) = TAGIHAN (7 Characters)

Pattern Data

Pattern = TAGIHAN

Length (m) = 7

Index: 0:T - 1:A - 2:G - 3:I - 4:H - 5:A - 6:N

PreBmBc Steps (Bad Character Table)

Formula:

$PreBmBc[c] = (m-1) - \text{last position}(c)$

Where last position = the rightmost index of character c.

The index stored for duplicate characters is the last position in the pattern.

If the character is not in the pattern (default), it is m.

Calculation:

T → last position = 0 →  $PreBmBc[T] = 6 - 0 = 6$

A → last position = 5 →  $PreBmBc[A] = 6 - 5 = 1$

G → last position = 2 →  $PreBmBc[G] = 6 - 2 = 4$

I → last position = 3 →  $PreBmBc[I] = 6 - 3 = 3$

H → last position = 4 →  $PreBmBc[H] = 6 - 4 = 2$

N → last position = 6 →  $PreBmBc[N] = 6 - 6 = 0$

Other characters → default = m = 7

**Table 1.** Prebmbc for the TAGIHAN pattern

Character	Last Position	Calculation	PreBmBc Value
T	0	6 - 0	6
A	5	6 - 5	1
G	2	6 - 2	4
I	3	6 - 3	3
H	4	6 - 4	2
N	6	6 - 6	0
Others		Default = 7	7

b. PreBmGs Step (Match Heuristic)

This step is performed to obtain the Match Heuristic value. The MH assessment process begins by arranging suffix patterns from right to left and vice versa from left to right, which is then followed by a shift analysis based on the suffix formed from right to left.

PreBmGs Calculation for "TAGIHAN"

Find matching suffix:

N → only occurs in the final position

AN → occurs at the end (AN) and also has an A at indices 1 & 5, but does not match AN.

HAN → unique.

IHAN → unique.

GIHAN → unique.

AGIHAN → unique.

TAGIHAN → Only full matches

So, no long suffix appear twice in the pattern.

Because there is no suffix repetition:

1. For all mismatch positions, the pattern must be shifted by a full  $m = 7$ , except for the mismatch at the end.
2. Mismatch at the end (index 6, letter N) → can be shifted by 1 (because you can still try the pattern again from the right).

PreBmGs Table for "TAGIHAN"

**Table 2.** PreBmGs for the TAGIHAN pattern

Position i (mismatch)	Letter	Matching Suffix (after i)	Shift (PreBmGs[i])
0 (T)	T	"AGIHAN"	7
1 (A)	A	"GIHAN"	7
2 (G)	G	"IHAN"	7
3 (I)	I	"HAN"	7
4 (H)	H	"AN"	7
5 (A)	A	"N"	7
6 (N)	N	""	1

So, for the "TAGIHAN" pattern, the PreBmGs table contains almost all 7s because the suffix don't repeat, with the only exception being the last position (N) → shift by 1. So, if a mismatch occurs in the middle of the pattern, the pattern will immediately be shifted completely, speeding up the search.

**Table 3.** Suffix for the "TAGIHAN" pattern

Suffix (Right → Left)	Prefix	Suffix (Left → Right)
N	T	T
AN	A	TA
HAN	G	TAG
IHAN	I	TAGI
GIHAN	H	TAGIH
AGIHAN	A	TAGIHA
TAGIHAN	N	TAGIHAN

### Use Case Diagram

A use case diagram is a representation in the Unified Modeling Language (UML) that visualizes the relationships between a system and the actors interacting with it. This diagram is typically used in the early stages of system development to identify and design core functionality from a user perspective. The following is a use case diagram for designing a web-based repository:



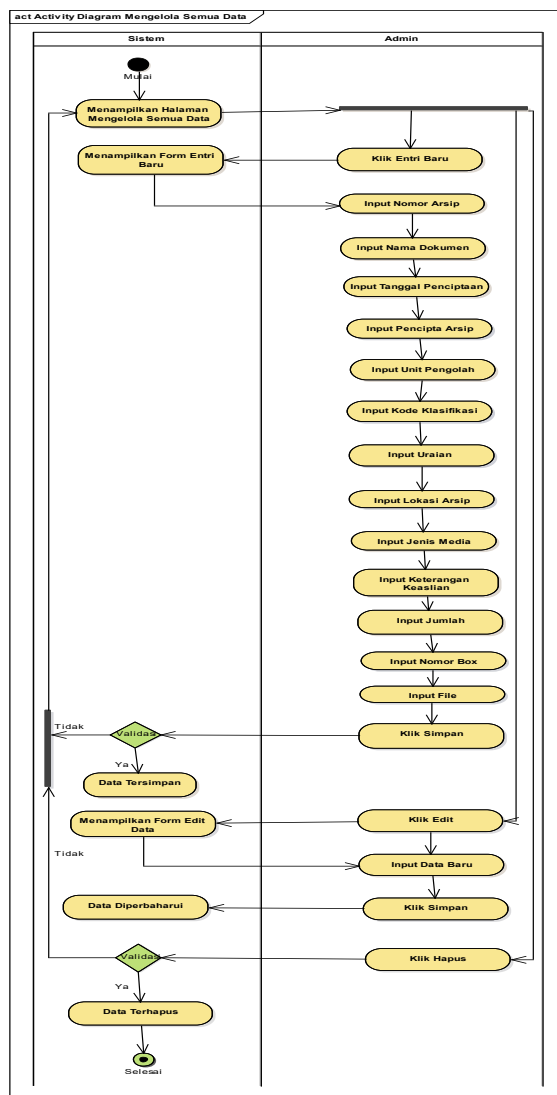

Figure 2. Activity Diagram for Managing All Admin Data

Document Search Activity Diagram

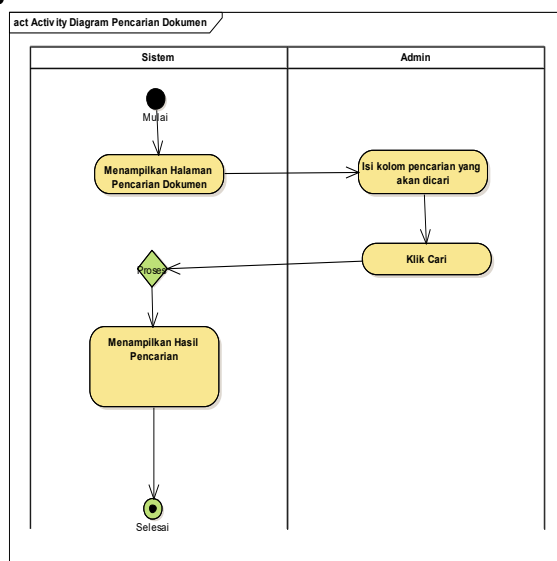
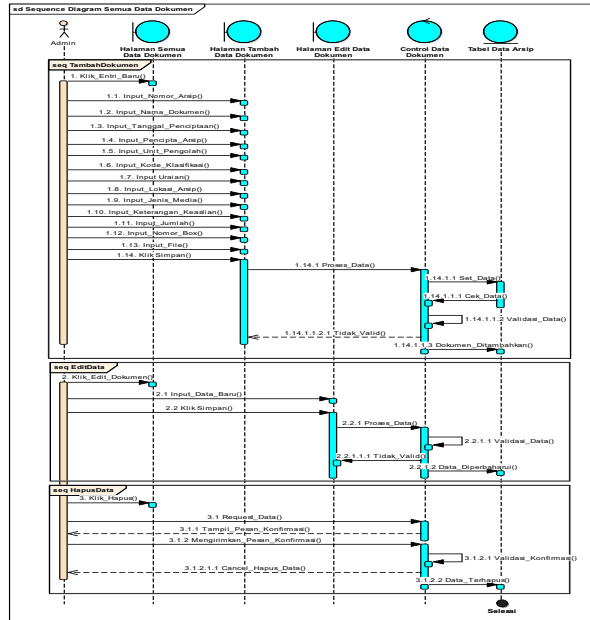

Figure 3. Document Search Activity Diagram

**Sequence**

Sequence diagrams are constructed as a continuation of activity diagrams, with the aim of depicting the sequence of activities and communication between components in the system.

**Sequence Diagram of All Document Data**



**Figure 4.** Sequence Diagram of All Data

**Document Search Sequence Diagram**

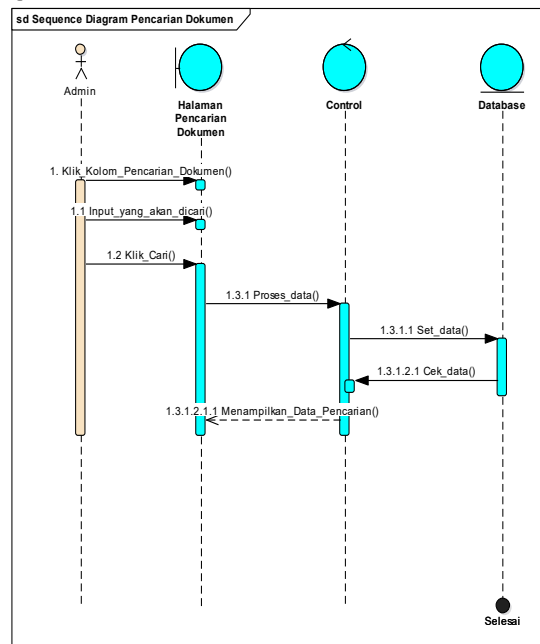

**Figure 5.** Document Search Sequence Diagram

**Entity Relationship Diagram (ERD)**

Entity Relationship Diagram describes the database design that will be used, as in the following diagram:

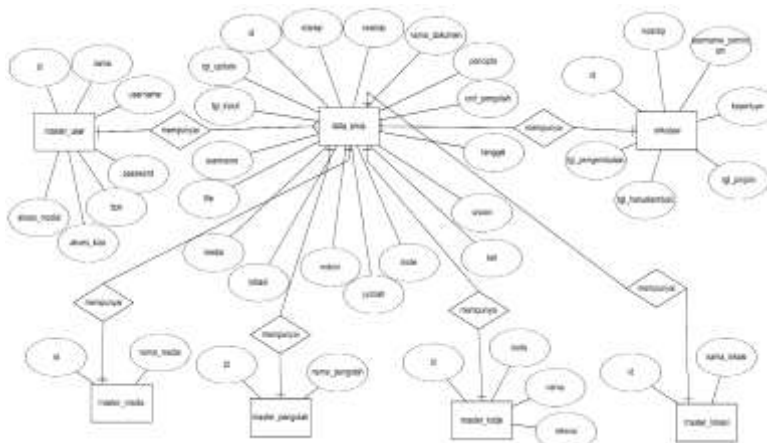

Figure 6. Entity Relationship Diagram

ERD to LRS Transformation

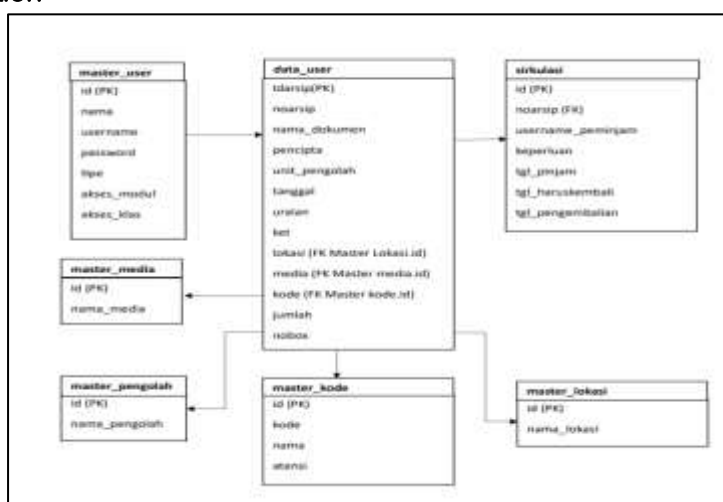

Figure 7. ERD to LRS Transformation

Database Specifications

Table 4. master\_user table

No	Column Name	Data Type	Description
1	id	int	NOT NULL, PK
2	name	varchar(255)	NOT NULL
3	username	varchar(255)	NOT NULL
4	password	varchar(255)	NOT NULL
5	type	enum('admin','operator','user')	NOT NULL, Table Roles
6	access_class	text	NOT NULL
7	access_module	text	NOT NULL

System Prototype

Login Prototype

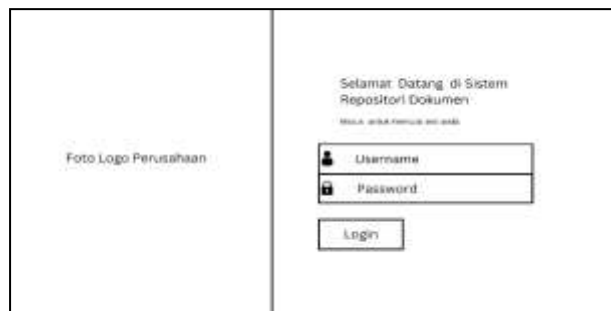

Figure 9. Login Prototype

### Dashboard Prototype

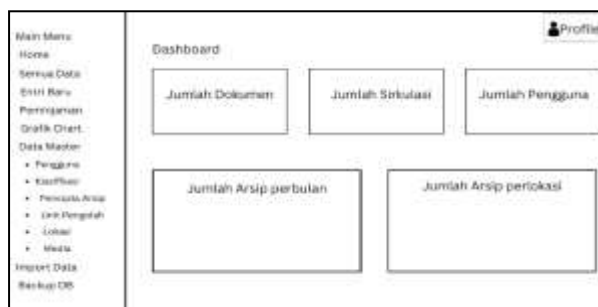

Figure 10. Dashboard Prototype

### System Implementation

#### Login Page Implementation

This page is designed to allow users to log in securely to the system. Users need to enter a username and password to access the respective role page to access the application dashboard.



Figure 11. Login Page

#### Admin Dashboard Page Implementation

The admin dashboard page serves as the main page for admins, with several menus for data processing. Admins have access to document data management, charts, document borrowing, and master data document searches. The menu consists of user, classification, archive creator, processing unit, location, and media. It also includes menus for data import and database backup.



Figure 12. Admin Dashboard Page

### Document Search Page Implementation

The Document Search Page displays the Boyer-Moore algorithm search field by entering keywords from the archive number or document name. You can view the search speed from the console.



Figure 13. Document Search Page

### Comparison Results and Algorithm Testing

A comparative analysis of search methods was conducted in the context of a document archiving system. This system supports two approaches to searching documents using names: using the Boyer-Moore algorithm and a conventional method without a specific algorithm. Both methods were implemented in the system for evaluation purposes. The following presents the results of document search time measurements using the Boyer-Moore algorithm compared to the search process without using an algorithm. Ten data sets were used for comparison of search times.

Table 5. Comparison of Search Times

Pattern	Boyer Moore Search (seconds)	Search Without Algorithm (seconds)
Sertifikat Laik Fungsi Mall The Park Sawangan	3.117919	44.455051
Surat Permohonan Izin Sondir	2.846923	43.712854
NIB PT. Sinsu Prisma Sinergi Indonesia	3.030029	45.132875
SK Pengesahan Kemenkumham PT. SINSU PRISMA SINERGI INDONESIA	3.042968	44.148921
Invoice PT. INDOCONSULT CIPTA PRESTATAMA	3.018066	46.412944
IZIN LOKASI PT. MELIA ARJUNA BEJANA	3.097167	42.939186
NIB PT. MELIA ARJUNA BEJANA	3.210937	44.049024
BUKTI PENDAFTARAN BERKAS PENDAFTARAN ONLINE	3.088867	46.185016
PERJANJIAN PENYEDIA JASA KAJIAN DAN PENGURUSAN SERTIFIKAT LAIK FUNGSI CITIPLAZA BOGOR	2.809814	48.004865
SITEPLAN RUKO VETERAN BOGOR	3.390136	44.808149

Based on the analysis of the existing document management system at PT. Prasty Mitra Solusindo, the operational process involves three main roles: director, admin, and employees. The director functions primarily as a supervisor who monitors document data, views reports, and performs document searches when necessary. The admin plays the central operational role by managing user accounts, controlling system access rights, organizing document classifications, managing archive data, and maintaining the database through backup and import processes [12]. Employees act as system users who can access document information, input new document data, and monitor document charts available in the system. This role distribution ensures that document management activities are structured, controlled, and accessible according to the authority of each user within the organization [13].

The implementation of the Boyer Moore algorithm in the repository system significantly improves the efficiency of document retrieval. The algorithm operates through two main heuristic stages: the *bad character rule* (PreBmBc) and the *good suffix rule* (PreBmGs). In the example pattern "TAGIHAN", the preprocessing stage calculates the shift values for each character using the formula  $\text{PreBmBc}[c] = (m-1) - \text{last position}(c)$ . The results show that characters appearing earlier in the pattern produce larger shift values, allowing the algorithm to skip several comparisons when mismatches occur. The good suffix heuristic further optimizes the process by identifying repeating suffix patterns and determining how far the search pattern should be shifted. Since the pattern "TAGIHAN" does not contain repeated suffix structures, most mismatch positions produce a full shift of seven characters, except the last position, which allows a shift of one character. This mechanism enables the system to move quickly across text data without comparing every character sequentially [14].

System modeling was carried out using several UML diagrams to ensure that the developed application structure reflects the operational workflow. The use case diagram illustrates the interactions between actors and the system, showing how directors, admins, and employees interact with repository features. The activity diagrams describe the sequence of processes such as managing document data and performing document searches. The sequence diagrams further detail the communication between system components during document management and retrieval operations. In addition, the Entity Relationship Diagram (ERD) defines the database structure used to store repository data, including user information, document classification, and archive metadata. The transformation from ERD to Logical Record Structure (LRS) ensures that the database design can be implemented effectively in the system.

The database specification defines the structure of the `master_user` table, which stores information about system users including identification number, username, password, and role type. The system distinguishes between several access levels such as administrator, operator, and general user. Additional attributes such as `access_class` and `access_module` allow the system to manage user permissions and module accessibility more precisely, ensuring data security and controlled system usage [15].

The developed system prototype includes several main interfaces such as the login page, dashboard page, and document search page. The login interface ensures secure system access by requiring users to authenticate using their username and password. After authentication, users are directed to the dashboard interface according to their role. The admin dashboard provides comprehensive document management features including document classification, archive creation, data import, and database backup. Meanwhile, the document search interface allows users to locate archives efficiently by entering keywords related to document titles or archive numbers. The search process is executed using the Boyer Moore algorithm, and the system displays the search performance through the system console [16].

The testing phase compared the performance of document searches using the Boyer Moore algorithm with conventional search methods. The results indicate that searches using the Boyer Moore algorithm consistently require approximately 2.8 3.3 seconds, whereas conventional searches without a specialized algorithm require 42 48 seconds. This substantial difference demonstrates that the Boyer Moore algorithm significantly accelerates document retrieval within the repository system. The improvement occurs because the algorithm does not perform sequential comparisons across the entire text but instead uses heuristic shift rules that skip irrelevant sections of the data [17].

To strengthen the validity of these findings, the results were compared with previous studies related to digital archive systems and text-search algorithms. The comparison shows that the observed improvement in search performance is consistent with previous research indicating that the Boyer Moore algorithm is one of the most efficient string-matching algorithms for text retrieval systems [2]. However, the implementation

in this research provides a practical contribution by applying the algorithm directly to a real organizational document management environment. Any differences with earlier studies may arise from variations in dataset size, document structure, or system architecture used in each research context.

The phenomena observed during the testing process also align with theoretical expectations regarding the performance of heuristic search algorithms. Faster search times occur because the Boyer Moore algorithm utilizes preprocessing tables that allow the search pattern to shift several characters when mismatches occur [18]. When the experimental results matched theoretical predictions, the improvement could be attributed to the algorithm's ability to minimize redundant comparisons. If minor variations occurred in certain cases, they could be explained by differences in document length, keyword complexity, or database query conditions.

## 5. Conclusion

Based on the results of the research entitled "*Design and Construction of a Web-Based Repository System Using the Boyer Moore Algorithm for Efficient Document Management at PT. Prasty Mitra Solusindo,*" several conclusions can be formulated. First, the development of a web-based repository system has successfully addressed problems related to the management of physical documents, such as the risk of document loss, physical damage, and limited storage space. Through the digitization of archives, document management becomes more organized, secure, and easily accessible for authorized users within the company. The system also facilitates structured document classification, storage, and monitoring processes that support more effective administrative activities.

Second, the integration of the Boyer Moore algorithm in the document search feature significantly improves the efficiency of document retrieval. The testing results indicate that the algorithm provides faster search performance compared to conventional search methods without a specific algorithm. This improvement accelerates the process of locating documents required in daily operational activities and reduces the time spent searching for archive data within the system.

Third, the implementation of access control mechanisms based on user roles ensures that system usage remains secure and well managed. Different levels of access for directors, administrators, and employees enable the protection of important company documents while maintaining data integrity and preventing unauthorized use or modification of archived files.

Although the developed system has demonstrated effective performance, several recommendations can be proposed for further development. Future research may expand the repository system by integrating additional search optimization algorithms or combining multiple algorithms to further improve search accuracy and efficiency, especially when dealing with larger datasets. In addition, the system could be enhanced by implementing advanced security mechanisms such as encryption, multi-factor authentication, or audit trails to strengthen data protection.

Further studies may also evaluate system performance using larger document collections and different organizational environments to test scalability and adaptability. By conducting broader testing and system improvements, the repository platform can continue to evolve into a more robust and comprehensive document management solution.

## 6. References

- [1] N. Firduas And D. Irfan, "Rancang Bangun Sistem Informasi Arsip Berbasis Web Menggunakan Framework Codeigniter," *Jurnal Vocational Teknik Elektronika Dan Informatika*, Vol. 8, No. 1, Pp. 45–54, Mar. 2020, [Online]. Available: [Http://Ejournal.Unp.Ac.Id/Index.Php/Voteknika/Index](http://Ejournal.Unp.Ac.Id/Index.Php/Voteknika/Index)
- [2] S. Nadilla, R. Tjut Adek, And R. Suwanda, "Implementasi Algoritma Boyer-Moore Dan Brute Force Untuk Pencarian Tafsir Di Ensiklopedia Al-Qur'an Berbasis Website," *Rabit: Jurnal Teknologi Dan Sistem Informasi Univrab*, Vol. 10, No. 2, Pp. 1393–1404, Jul. 2025, Doi: 10.36341/Rabit.V10i2.6552.
- [3] P. Dede Andika Putra, I. G. Putu Krisna Juliharta, And I. N. Purnama, "Perancangan Sistem Informasi Pengarsipan Dokumen Berbasis Website Pada Sekolah Dasar Negeri 22 Dauh Puri," *Jati (Jurnal Mahasiswa Teknik Informatika)*, Vol. 8, No. 1, Pp. 872–879, Mar. 2024, Doi: 10.36040/Jati.V8i1.8887.
- [4] R. Widolaras And M. N. Ikhsanto, "Sistem Pendukung Keputusan Pemilihan Tabir Surya Wajah Untuk Kulit Berminyak Menggunakan Metode Analytical Hierarchy Process," *Jurnal Teknologi Informatika Dan ...*, Vol. 8, No. 2, Pp. 431–440, 2022.
- [5] A. Amrin, D. R. Savero, And M. Alawi, "Model Waterfall Untuk Perancangan Sistem Informasi Pengelolaan Data Arsip Gudang Pada Disdukcapil Kota Depok," *Insantek*, Vol. 3, No. 1, Pp. 6–11, May 2022, Doi: 10.31294/Instk.V3i1.1135.
- [6] M. Martin And L. Nilawati, "Rancang Bangun Sistem Informasi Peminjaman Arsip Berbasis Web," *Jurnal Teknologi Dan Sistem Informasi Bisnis*, Vol. 6, No. 3, Pp. 427–434, Jul. 2024, Doi: 10.47233/Jteksis.V6i3.1326.
- [7] M. Kumar, V. Dwivedi, A. Sanyal, P. Bhatt, And R. Koshariya, "Parental Security Control," In *2021 Thirteenth International Conference On Contemporary Computing (Ic3-2021)*, New York, Ny, Usa: Acm, Aug. 2021, Pp. 469–474. Doi: 10.1145/3474124.3474196.
- [8] F. Fauzan, N. Faizah, And L. Koryanto, "Android Based Application For Searching Indekos In Pasar Minggu Jakarta South With Location Based Service (Lbs) Method," *Journal Mobile Technologies (Jms)*, Vol. 1, No. 1, Pp. 1–7, Feb. 2023, Doi: 10.59431/Jms.V1i1.128.
- [9] F. Firdaus, R. Muntaqo, And E. Trisnowati, "Analysis Of Student Readiness For Blended Learning Model Implementation In Industrial Era 4.0," *Indonesian Journal Of Science And Education*, Vol. 4, No. 1, P. 48, May 2020, Doi: 10.31002/Ijose.V4i1.2309.
- [10] Y. E. Rachmad *Et Al.*, *Rekayasa Perangkat Lunak*. Pt. Sonpedia Publishing Indonesia, 2023.
- [11] R. A. A. And D. Kurniawan, "Perancangan User Experience Aplikasi Android Konsultasi Skripsi Dengan Metode User Centered Design," *Jurnal Teknologi Dan Sistem Informasi Bisnis*, Vol. 5, No. 3, Pp. 183–189, Jul. 2023, Doi: 10.47233/Jteksis.V5i3.834.
- [12] M. Muliadi, M. Andriani, And H. Irawan, "Perancangan Sistem Informasi Pemesanan Kamar Hotel Berbasis Website (Web) Menggunakan Data Flow Diagram (Dfd)," *Jisi: Jurnal Integrasi Sistem Industri*, Vol. 7, No. 2, Pp. 111–122, Sep. 2020, Doi: 10.24853/Jisi.7.2.111-122.
- [13] M. Taufik, S. F. C. Haviana, And D. Kurniadi, "Utilization Of Location-Based Services For The Design Of Agricultural Sales Applications," *Jurnal Transformatika*, Vol. 15, No. 2, Pp. 128–132, Jan. 2018, Doi: 10.26623/Transformatika.V15i2.598.
- [14] S. Mariko, "Aplikasi Website Berbasis Html Dan Javascript Untuk Menyelesaikan Fungsi Integral Pada Mata Kuliah Kalkulus," *Jurnal Inovasi Teknologi Pendidikan*, Vol. 6, No. 1, Pp. 80–91, Apr. 2019, Doi: 10.21831/Jitp.V6i1.22280.
- [15] D. Ariestanto, D. Abdullah, M. Muntahanah, And A. Wijaya, "Implementasi Location Based Service Dalam Perancangan Aplikasi Pencarian Lokasi Tambal Ban Di Kota Bengkulu," *Jurnal Media Infotama*, Vol. 21, No. 1, Pp. 357–364, Apr. 2025, Doi: 10.37676/Jmi.V21i1.8170.
- [16] B. C. Putra, D. Anubhakti, And G. P. Utama, "Analisa Dan Desain Sistem Monitoring Transaksi Data Center Dan Disaster Recovery Center Studi Kasus Pada Direktorat Pengelolaan Informasi

- Administrasi Kependudukan Ditjen Kependudukan Dan Pencatatan Sipil,” *Idealis : Indonesia Journal Information System*, Vol. 5, No. 2, Pp. 135–140, Aug. 2022, Doi: 10.36080/Idealis.V5i2.2938.
- [17] Y. Anggraini, D. Pasha, D. Damayanti, And A. Setiawan, “Sistem Informasi Penjualan Sepeda Berbasis Web Menggunakan Framework Codeigniter,” *Jurnal Teknologi Dan Sistem Informasi*, Vol. 1, No. 2, Pp. 64–70, Dec. 2020, Doi: 10.33365/Jtsi.V1i2.236.
- [18] Nurman Hidayat And Kusuma Hati, “Penerapan Metode Rapid Application Development (Rad) Dalam Rancang Bangun Sistem Informasi Rapor Online (Siraline),” *Jurnal Sistem Informasi*, Vol. 10, No. 1, Pp. 8–17, Feb. 2021, Doi: 10.51998/Jsi.V10i1.352.